

# Keysight E8257D/67D PSG Signal Generators Add Option 1ED (Type-N Connector)

Kit Part Numbers:

E8251-60386 - For Front RF Output

E8251-60396 - For Rear RF Output

Notice: This document contains references to Agilent. Please note that Agilent's Test and Measurement business has become Keysight Technologies. For more information, go to [www.keysight.com](http://www.keysight.com).

## Installation Note

Part Number: E8251-90386  
Printed in USA August 2014

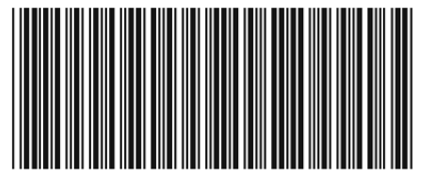

E8251-90386

**Notice**

The information contained in this document is subject to change without notice.

Keysight Technologies makes no warranty of any kind with regard to this material, including but not limited to, the implied warranties of merchantability and fitness for a particular purpose.

Keysight Technologies shall not be liable for errors contained herein or for incidental or consequential damages in connection with the furnishing, performance, or use of this material.

---

## Add Option 1ED (Type-N Connector)

### Kit Part Numbers: E8251-60386 and E8251-60396

Product Affected: .....	E8257D/67D
Serial Numbers: .....	All
Options: .....	
To Be Performed By: .....	(X) Agilent Technologies Service Center (X) Personnel Qualified by Agilent Technologies (X) Customer
Estimated Installation Time: .....	1.0 hour
Estimated Verification Time: .....	1.0 hour

### Introduction

This upgrade kit adds Option 1ED (Type-N Connector) to the E8257D (Analog) and E8267D (Vector) PSG Signal Generators.

Installation includes the following major steps, starting on [page 5](#):

1. Check signal generator functionality.
2. Remove the outer and inner signal generator covers.
3. Remove the front panel (for instruments with front RF Output Connectors only)
4. Install Option 1ED.
5. Re-assemble the signal generator.
6. Verify signal generator calibration.

## Installation Kit Parts List

**Table 1 E8251-60386, RF Front Output**

Item	Quantity	Description	Part Number
1	1	Installation Note	E8251-90386
2	1	Type-N Connector Assembly	E8251-60106

**Table 2 E8251-60396, RF Rear Output**

Item	Quantity	Description	Part Number
1	1	Installation Note	E8251-90386
2	1	Type-N Connector Assembly	E8251-60107

### Tools Required

- TORX T-10 driver
- TORX T-15 driver
- TORX T-20 driver
- 5/16" open-ended wrench
- Needle-nose pliers

## Safety Considerations

---

**WARNING**      **Before you disassemble the signal generator, turn the power switch off and unplug the power cord. Failure to unplug the signal generator can result in personal injury.**

---

---

**CAUTION**      Electrostatic discharge (ESD) can damage or destroy electronic components. All work on electronic assemblies should be performed at a static-safe workstation.

---

### Check Signal Generator Functionality

Use the following procedure to confirm that the signal generator powers up and the internal check identifies no errors. The internal check evaluates the operation of the signal generator and returns an error message if it detects a problem.

---

**NOTE**      When the signal generator is first connected to ac line power, the error message `ERROR 514, Reference Oven Cold` occurs which causes both the `OVEN COLD` annunciator and the `ERR` annunciator to turn on.

After approximately five minutes, the `OVEN COLD` annunciator automatically clears, but the `ERR` annunciator remains on until all errors are cleared from the error queue.

---

1. Turn on the signal generator and let it warm up for at least five minutes.
2. Run the signal generator self-test by pressing **Utility > Instrument Info/Help Mode > Self Test > Run Complete Self Test**. Upon completion a summary of the self-test will be displayed. Use the *E8257D/67D PSG Service Guide* to troubleshoot any failures detected by the test.

---

**NOTE**      Some circuits may require up to 50 minutes to warm up before passing the self-test. If self-tests continue to fail after 50 minutes of warm up, troubleshoot the instrument.

---

3. Check to see if the `ERR` annunciator is on.
  - If the `ERR` annunciator is on, review the error messages in the error queue by pressing **Utility > Error Info**. The first page of error messages in the error queue appears in the display text area. (Refer to the signal generator error messages document for information about each error message.)

After resolving all problems causing errors, press **Clear Error Queue(s)**.

  - If the `ERR` annunciator is off, the signal generator functionality check has passed.

## **Remove the Outer and Inner Signal Generator Covers**

### **Remove the Outer Cover**

Refer to [Figure 1](#).

1. Disconnect the power cord.
2. Using a T-20 driver, loosen the two screws (1) and remove the strap handle (2).
3. Using a T-15 driver, remove the center screws (3) on the four rear-panel feet (4).
4. Remove the four bottom feet (5) from the cover by lifting the tab and sliding the foot toward the tab.
5. Place the signal generator on its side.
6. Tilt the signal generator forward and slide the outer cover (6) back to remove it from the frame.

### **Remove the Inner Top Cover**

Refer to [Figure 2](#).

1. Using a T-10 driver, remove the screws (1) from the inner-top cover (2). There are twelve screws for E8257D and eleven screws for E8267D.
2. Remove the inner-top cover.

**Figure 1**      **Outer Cover Removal**

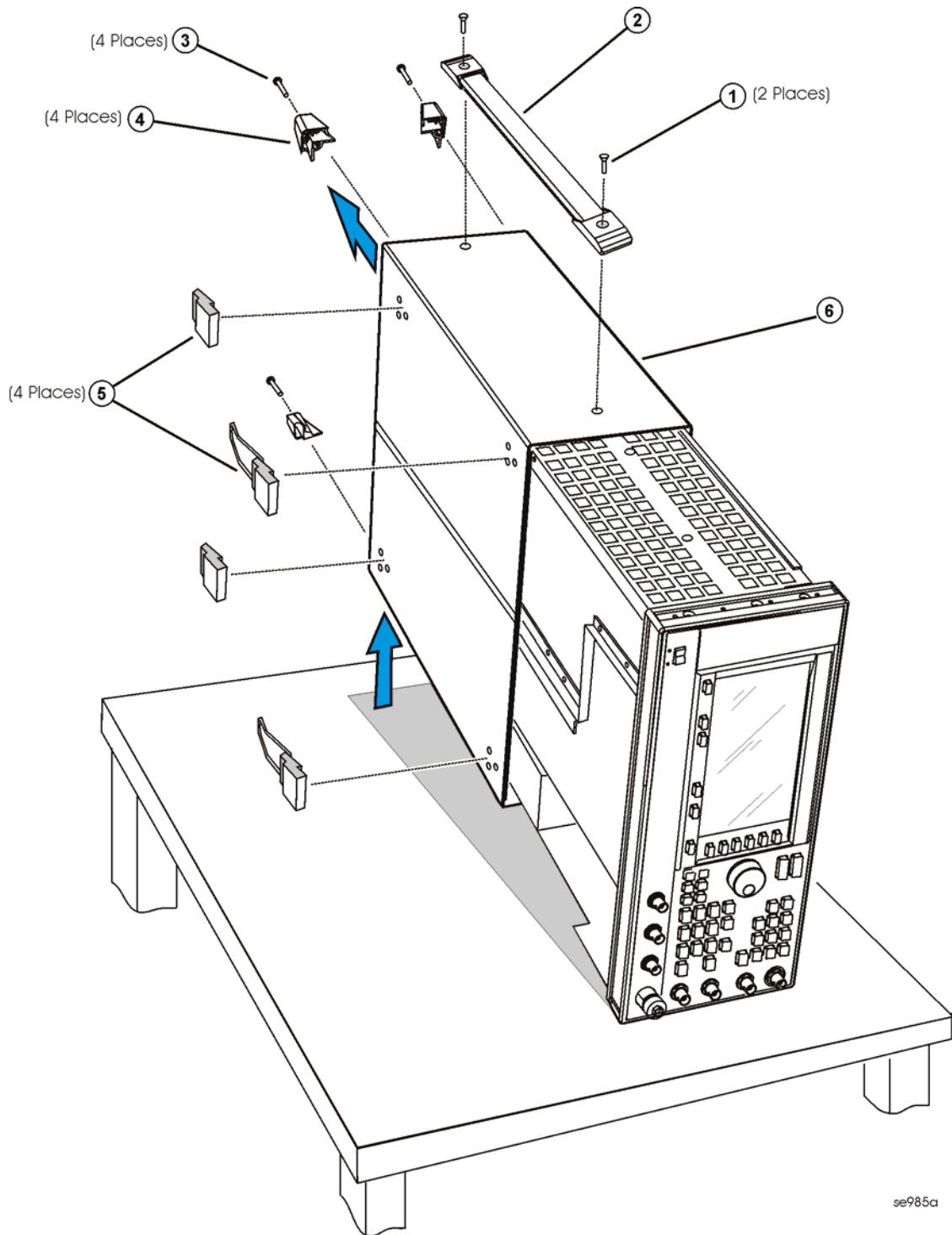

se985a

**Figure 2**

**Inner Top Cover Removal**

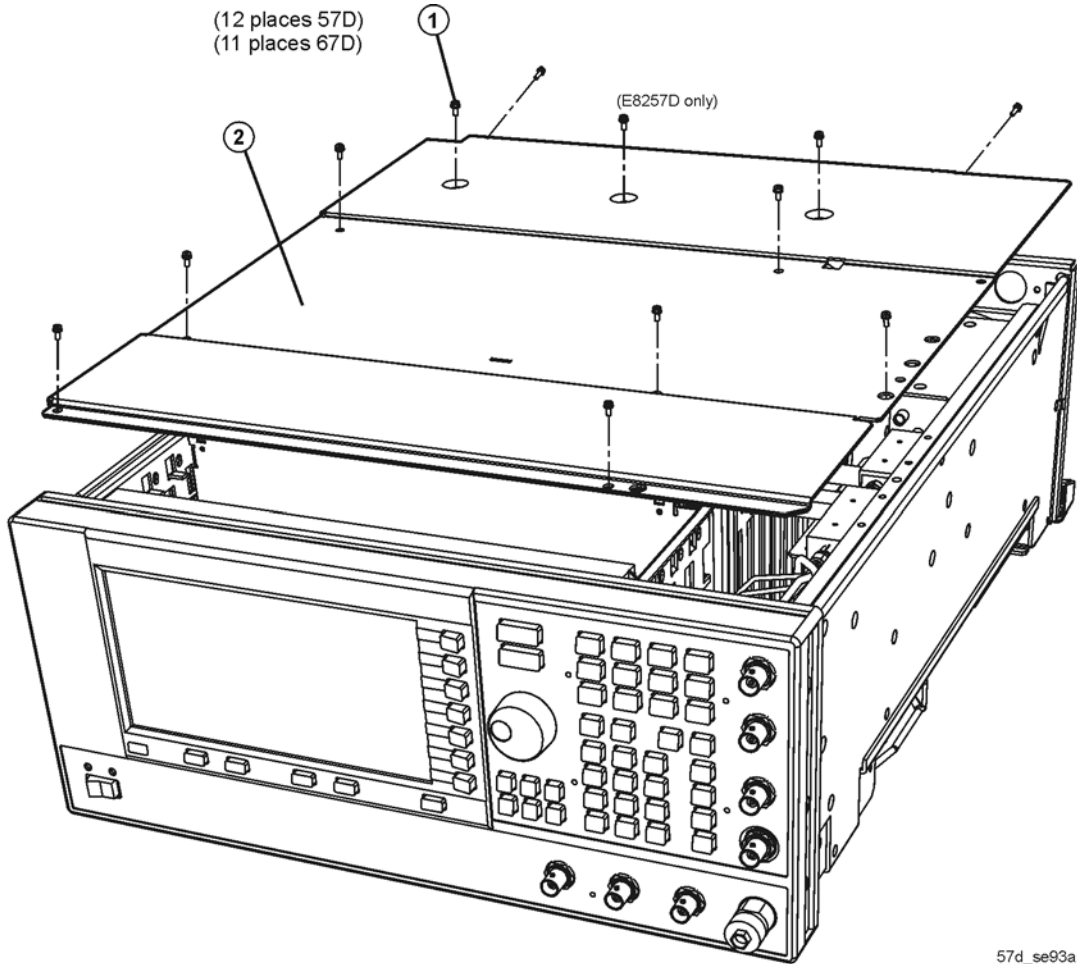

57d\_se93a

**Remove Front Panel (Instruments with Front RF Output Connectors Only)**

Refer to [Figure 3](#)

1. Using the T-10 driver, remove the four screws from the Baseband Generator cover (E8267D only).
2. Using the T-15 driver, remove the six screws (1) from the sides of the frame.
3. Using the T-10 driver, remove one screw from the top (2) and one screw from bottom (3) of the frame.

---

**CAUTION** Before removing the front panel from the signal generator, lift and support the front of the signal generator's frame.

---

4. Slide the front panel over the RF output connector.
5. Using the needle-nose pliers, disconnect the following flexible cables:
  - W1 (EXT 1 INPUT) from the A11 Pulse/Analog Modulation Generator J401.
  - W2 (EXT 2 INPUT) from the A11 Pulse/Analog Modulation Generator J402.



- W3 (LF OUTPUT) from the A11 Pulse/Analog Modulation Generator J403.
  - W4 ALC INPUT) from the A10 ALC J4.
  - W5 (PULSE/TRIGGER GATE INPUT) from the A11 Pulse/Analog Modulation Generator J201.
  - W6 (PULSE VIDEO OUTPUT) from the A11 Pulse/Analog Modulation Generator J203.
  - W7 (PULSE SYNC OUTPUT) from the A11J202.
  - W49 (I IN) from the A13J7 (E8267D only).
  - W50 (Q IN) from the A13J8 (E8267D only).
  - W51 (DATA) from the A31J500 (E8267D only).
  - W52 (DATA CLOCK) from the A31J501 (E8267D only).
  - W53 (SYMBOL SYNC) from the A31J502 (E8267D only).
6. Disconnect the A1W1 display cable from the A31 Motherboard P13.
  7. Disconnect the A4W1 inverter cable from the A31 Motherboard P12.
  8. Disconnect the W9 ribbon cable from the A31 Motherboard P11.
  9. Remove the front panel.

**Figure 3 Front Panel Removal**

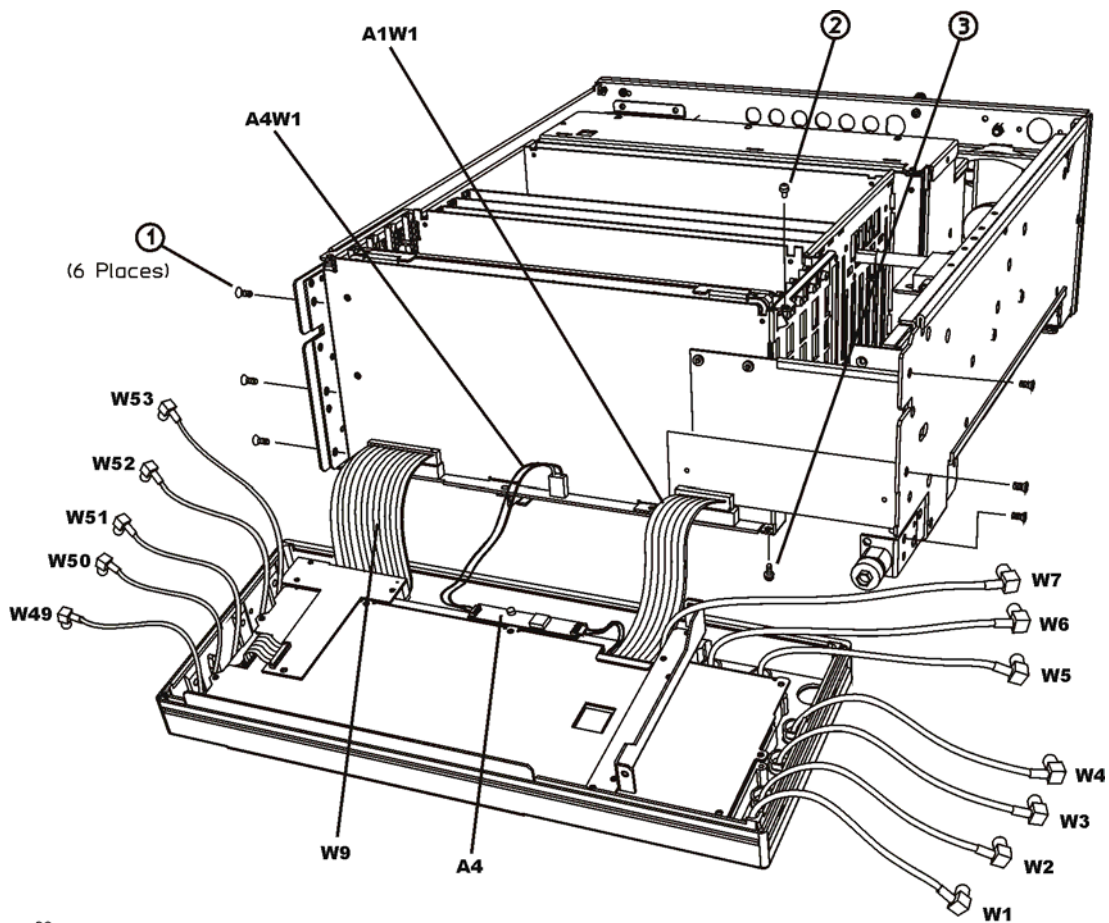

p-se98a

## **Install Option 1ED (Instruments with Front RF Output Connectors)**

1. Using the 5/6" open-wrench, remove the semi-rigid cable connected to the RF output connector.
2. Using the T-10 driver, remove the screw securing the connector to the instrument. The screw is on the outside edge of the connector.
3. Remove the old RF Output connector.
4. Install the Option 1ED Type-N connector by reversing the removal process, steps 1 and 2.
5. Reinstall the front panel by reversing the order of removal, see [page 8](#).

## **Install Option 1ED (Instruments with Rear RF Output Connectors)**

1. Using the 5/6" open-wrench, remove the semi-rigid cable connected to the RF output connector.
2. Using the T-10 driver, remove the two screws securing the connector to the rear panel of the instrument.
3. Remove the old RF Output connector.
4. Install the Option 1ED Type-N connector by reversing the removal process, steps 1 and 2.

## **Re-Assemble the Signal Generator**

Refer to [Figure 1](#) and [Figure 2](#).

1. Reinstall the inner and outer instrument covers by reversing the order for removal.
2. Torque all T-10 screws to 9 in-lbs.
3. Torque all T-15 and T-20 screws to 21 in-lbs.

## **Verify Signal Generator Calibration**

1. Turn the signal generator on and allow it to warm up for 30 minutes.
2. Perform the following adjustment and performance tests to verify signal generator calibration. Refer to the PSG Family Signal Generators Service Software:
  - Power Flatness Calibration
  - Self Tests
  - Maximum Leveled Output Power
  - Power Level Accuracy